

**BOOST/BUCK-BOOST/BUCK/CONTROLLER IC with External MOSFET**

**FEATURES**

- 5 - 60V input voltage range
- Single resistor programmable constant current driver
- Excellent constant current accuracy  $\pm 3\%$  typically
- 0.1V feedback reference voltage tailor-made for LED application
- Support Boost/Buck/Buck-Boost configuration
- DC Dimming & PWM dimming
- On-chip thermal shutdown at 170°C
- Fixed switching frequency 430kHz
- Dithering in oscillator frequency to simplify the EMI design
- Cycle-by-cycle current limit
- Over-current protection
- IC overvoltage protection
- 15 $\mu$ A shutdown current
- SO8-EP package

**GENERAL DESCRIPTION**

The T8332AD is designed to operate as a constant current source for driving high current LEDs. It is a current mode control IC which provides a good line transient response. The device can provide an excellent constant current accuracy of  $\pm 3\%$  typically. Moreover, the IC also provide several protection features like IC overvoltage protection, cycle by cycle current limit protection and thermal shutdown protection.

**PART NUMBER EXAMPLES**

PART NO.	PACKAGE
T8332AD	SO8-EP

**Applications**

- High Power LED Driver
- LED illuminance
- LCD backlight illumination
- Automotive interior lighting
- Automotive Headlights

**PIN ARRANGEMENT**

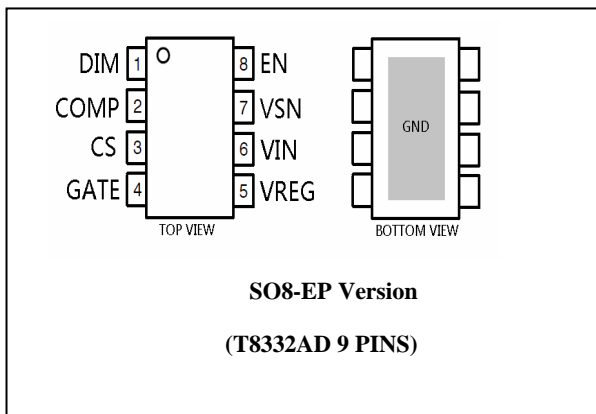

**TYPICAL APPLICATION**  
(BUCK-BOOST)

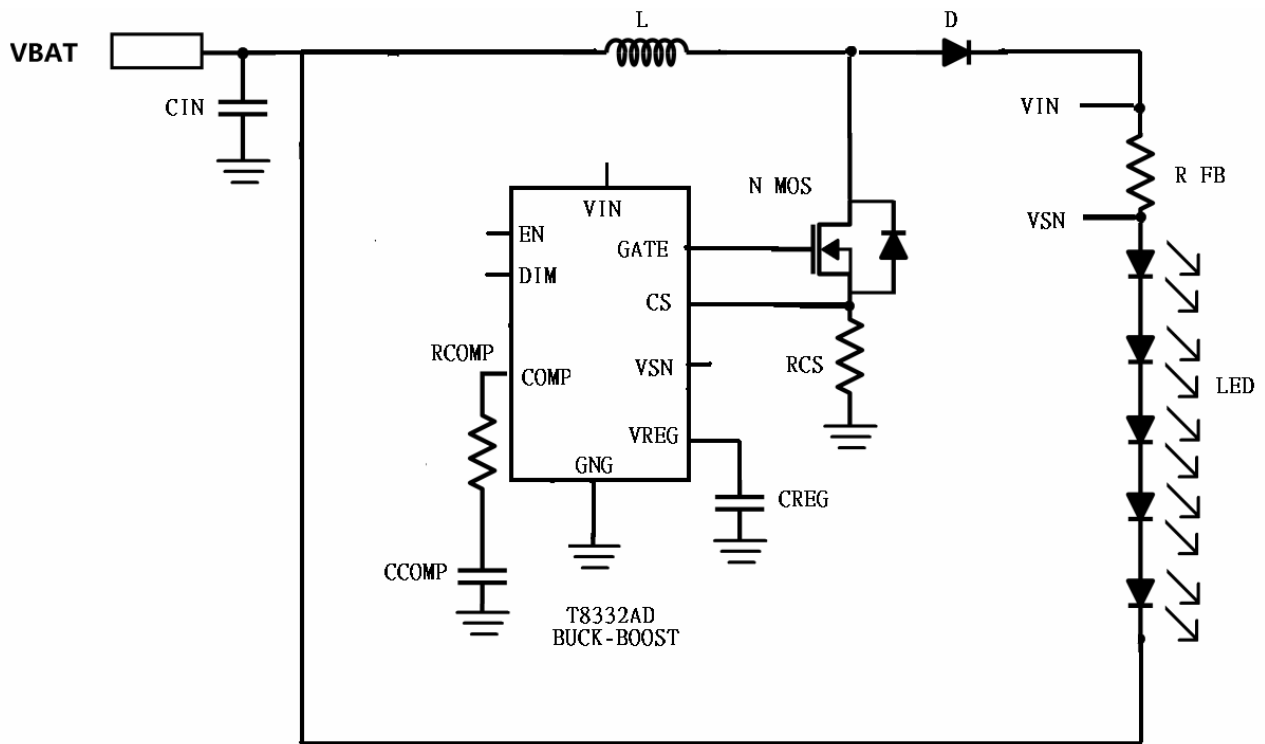

**PIN DESCRIPTION****T8332AD 9 PINS**

<b>Pin No.</b>	<b>Pin Name</b>	<b>Pin Description</b>
1	DIM	DC Dimming Function pin.
2	COMP	Compensation pin.
3	CS	Connect a resistor for the current mode control and cycle by cycle current limit function.
4	GATE	Switch gate drive
5	VREG	Internal regulator
6	VIN	Main supply
7	VSN	Load current sense –ve input
8	EN	Enable the chip
9	GND	Ground Pin. IC ground.(Package EP)

**ABSOLUTE MAXIMUM RATINGS**

<b>Parameter</b>	<b>Symbol</b>	<b>Value</b>	<b>Unit</b>
VIN pin voltage relative to GND		-0.3 to +60	V
DIM pin voltage relative to GND		-0.3 to +3.3	V
GATE		-0.3 to +10	V
VSN		VIN - 1	V
VREG		-0.3 to +8	V
COMP ENand CS pin voltage relative to GND		-0.3 to +5.5	V
Junction temperature range	T <sub>J</sub>	-40 to +150	°C
Maximum soldering temperature (at leads, 10sec)	T <sub>LEAD</sub>	300	°C
Storage temperature range	T <sub>S</sub>	-65 to +150	°C
Power dissipation at 70°C, SOP8-EP		800	mW

**Electrical Characteristics**

◆ Denotes the specifications which apply over the full operating temperature range  $T_j = -40^{\circ}\text{C}$  to  $+125^{\circ}\text{C}$ ,  $V_{\text{IN}} = 12\text{V}$ . Otherwise specifications are at  $T_A = 25^{\circ}\text{C}$ ,  $V_{\text{IN}} = 12\text{V}$ .

Symbol	Description	Conditions	Min.	Typ.	Max.	Unit	
<b>Supply and Reference</b>							
$V_{\text{INOVP}}$	$V_{\text{IN}}$ overvoltage			65.5		V	
$V_{\text{IN}}$	Operating voltage range	**	5		60	V	
$V_{\text{INUV}}$	$V_{\text{IN}}$ under-voltage	Decreasing $V_{\text{IN}}$	4.2	4.52		V	
$\Delta V_{\text{INUV}}$	$V_{\text{IN}}$ under-voltage hysteresis			260		mV	
$I_{\text{Q}}$	Operating quiescent current	$f_{\text{OSC}} = 430\text{kHz}$ ; Gate Driving at 1nF		2.5	3	mA	
$I_{\text{OFF}}$	Shutdown current	IC shutdown by $V_{\text{EN}} < V_{\text{EN,OFF}}$		20	26	$\mu\text{A}$	
$V_{\text{REG}}$	Regulation pin voltage	$V_{\text{IN}} = 12\text{V}$ , $I_{\text{REG}} = -10\text{mA}$	◆	6.5	7.3	8	V
$V_{\text{REGUV}}$	$V_{\text{REG}}$ under-voltage turn-off	Decreasing $V_{\text{REG}}$	3.8	4.2		V	
$\Delta V_{\text{REGUV}}$	$V_{\text{REG}}$ under-voltage hysteresis			350		mV	
$V_{\text{REGCL}}$	$V_{\text{REG}}$ current limit	$V_{\text{REG}}$ short to GND	◆	-25	-52	mA	
<b>Oscillator and Soft Start</b>							
$f_{\text{OSC}}$	Oscillator frequency		365	430	495	kHz	
<b>LED Current Sense and Control</b>							
$V_{\text{IDL}}$	Differential input voltage (Active)	EN=High, $V_{\text{IDL}} = V_{\text{IN}} - V_{\text{SN}}$		97	100	103	mV
$V_{\text{OCLED}}$	LED Over current threshold	EN=High, $V_{\text{SP}} - V_{\text{SN}}$		142	160	175	mV
$V_{\text{DIM,ON}}$	DC Dimming ON		0.15	0.206	0.25	V	
$V_{\text{DIM,MAX}}$	DC Dimming Control for Full Brightness	DC voltage on the DIM pin			2.3	V	
$V_{\text{DIM,MIN}}$	DC Dimming Control for Gate Driver OFF	DC voltage on the DIM pin			0.15	V	
<b>Gate Drive Output</b>							
$T_{\text{R}}$	Turn-On Rise Time	Loading Cap = 2.2nF (from 10% to 90%)			30	ns	
$T_{\text{F}}$	Turn-Off Fall Time	Loading Cap = 2.2nF (from 90% to 10%)			30	ns	
$V_{\text{OL}}$	Output low level		◆		0.2		
$V_{\text{OH}}$	Output high level			VREG		V	
$D_{\text{MAX}}$	Maximum duty cycle		◆	88	92	96	%

Symbol	Description	Conditions	Min.	Typ.	Max.	Unit	
<b>Switch Current Sense</b>							
SWOCP	Switch over-current threshold voltage		440	500	560	mV	
A <sub>CS</sub>	Voltage Gain			4		V/V	
I <sub>BIASS</sub>	Input Bias Current		-24	-32	-40	μA	
<b>Slope Compensation</b>							
I <sub>SLOPE</sub>	Slope Injection Current	Sawtooth current added to current sense (CS) pin		-97		μA	
<b>Logic Inputs and Outputs</b>							
V <sub>EN_ON</sub>	EN pin chip enable voltage threshold	V <sub>EN</sub> rising	♦	2		V	
V <sub>EN_OFF</sub>	EN pin chip disable voltage threshold		♦		0.8	V	
t <sub>DIS</sub>	Disable time	f <sub>OSC</sub> = 430kHz		38		ms	
<b>Dither Generator</b>							
f <sub>DITH</sub>	Dither Modulation Frequency	f <sub>OSC</sub> = 430kHz		6.7		kHz	
f <sub>SPREAD</sub>	Dither Frequency Range	% of switching frequency		+/-4		%	
<b>Protection</b>							
t <sub>FB</sub>	Fault blank timer	At start up, f <sub>OSC</sub> = 430kHz		2.4		ms	
V <sub>SCL</sub>	LED short protection voltage	V <sub>SP</sub> - V <sub>OUV</sub>		260	300	330	mV
V <sub>OCL</sub>	LED open protection voltage	V <sub>SP</sub> - V <sub>OUV</sub>		1.08	1.2	1.32	V
T <sub>SD</sub>	Over-temperature warning threshold*	Measured at junction, temperature increasing	*	170		°C	
T <sub>SDHYS</sub>	Over-temperature hysteresis*	Measured at junction, recovery = T <sub>SD</sub> -T <sub>SDHYS</sub>	*	35		°C	

♦ Function is correct but parameters are not guaranteed.

\*\* At VIN equals 5-6V and >50V, the part only guarantees GATE pin switching but not guarantee to follow the electrical parameters.

\*Parameters are not tested at production and guaranteed by design, characterization and process control.

**Block Diagram**

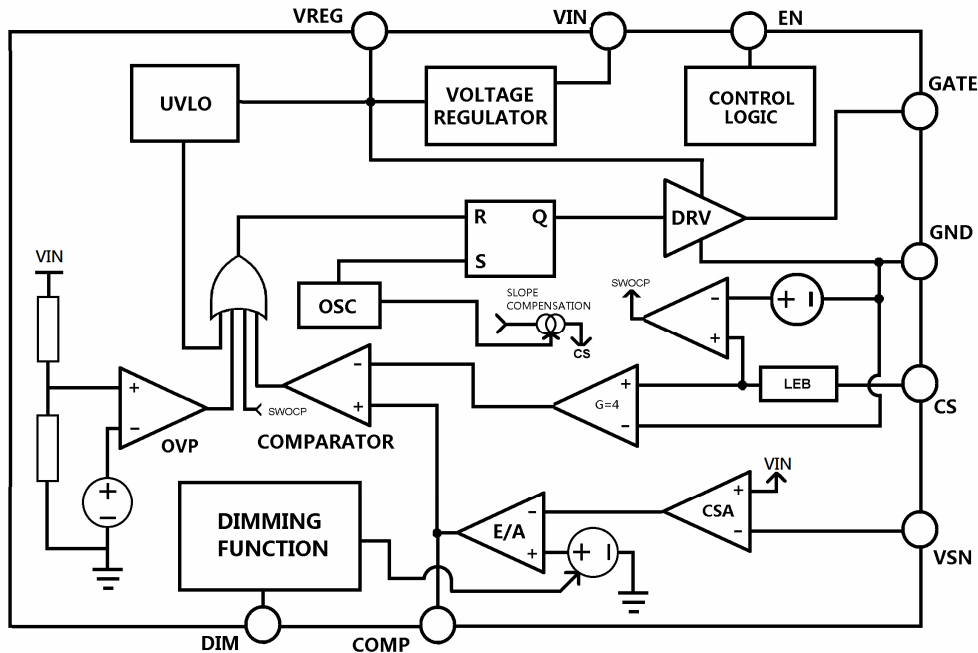

**T8332AD Block diagram**

**FUNCTIONAL DESCRIPTION**

T8332AD is a constant current LED driver which can be configured as a Boost, Buck and Buck-Boost converter. It depends on the user's choice of the number of LED in the output. Typical converter application circuits of T8332AD are shown in the next section.

**VIN**

The VIN is the power supply voltage pin for the supply to the control circuit of T8332AD. The pin has an UVLO function, once voltage on the pin reaches 4.52V; the IC is ready to start the operation. When the voltage on this pin falls below 4.78 V, the IC will be shutdown. (Note: A bypass capacitor must be connected close between this pin and GND.)

**VREG**

To provide a filtered output and to ensure the regulator is stable, a 2.2µF or above ceramic capacitor is required to be connected between VREG and GND. The ceramic type should be a quality type such as X5R, X7R, or X8R. The VREG pin voltage is for driving the external switching MOSFET. Normally, at 12V VIN, the VREG voltage is 7.3V typically. The UVLO point of the VREG is around 4.2V. Once the VREG is under 4.2V, the gate driver will be turned off and it will resume back to normal when the VREG voltage rises back to around 4.55V.

### Output current setting

The output LED current is determined by a combination of the LED sense resistor  $R_{SENSE}$ , the LED current threshold voltage,  $V_{IDL}$ , (100mV). For example, to program a 1A output current, the sensing resistor will be

$$R_{SENSE} = \frac{100mV}{1A} = 0.1\Omega$$

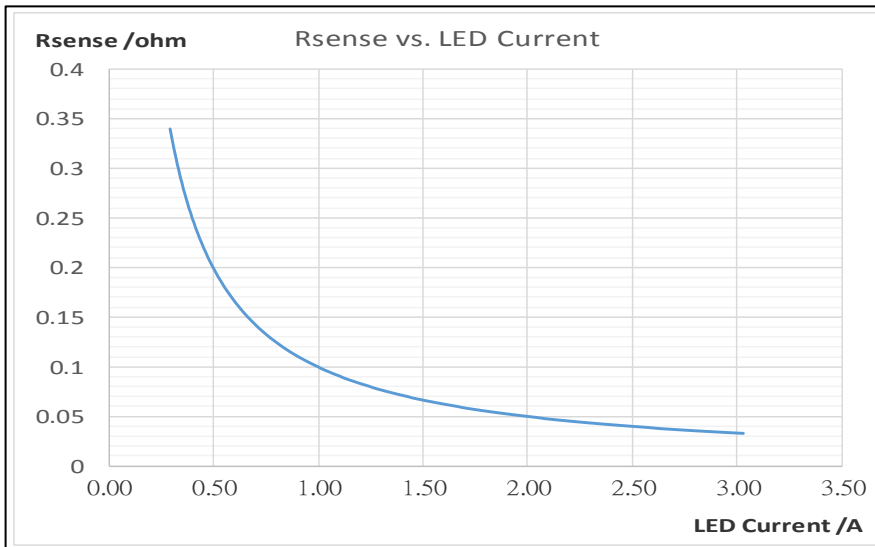

### Frequency Dithering

T8332AD has an internal frequency dither function to improve the EMI performance of the system. The internal frequency is hopping in a small frequency range to reduce the radiation at the switching frequency which simplifies the EMI design. The dither modulation frequency is 6.7kHz typically and the dither frequency range is  $\sim \pm 4\%$  typically.

### Enable Pin Function

The enable pin is to control the IC on/off operation. When the enable pin is pulled down over the disable time that stated in the datasheet ( $\sim 16340$  clock cycles which equivalent 38ms at switching frequency 430 kHz), the IC will completely shutdown and enter into the shutdown mode. The IC current consumption reduces to nearly  $20\mu A$ . This pin can also be used as direct PWM input for LED dimming.

**Switch current limit and over-current protection**

T8332AD has a switch current limiting function. When the CS pin voltage reaches the current limit threshold (~0.5V), the IC begins to count for the switch over current. Once the switch over current is over 8 clock cycles, the IC will enter into hiccup mode. The hiccup mode turns off the gate driver for 8192 clock cycles. After the hiccup mode, the IC will resume to monitor for the switch over current, if the switch over current stills exist and over 8 switching clock cycles, the IC will go to the hiccup mode again. Of course, if the switch over current condition removed, the IC will resume to normal operation. The switch over current limit equation is shown below.

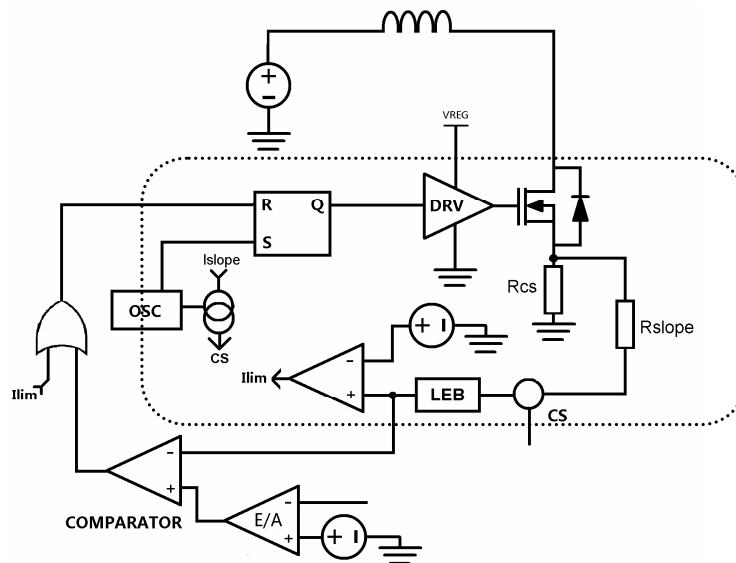

**Slope Compensation**

The slope compensation is to prevent subharmonic oscillations at duty cycles greater than 50% in continuous current conduction mode. A current source is provided at the CS pin as a sawtooth from 0 to 100µA. An external resistor, R<sub>SLOPE</sub>, connected between the CS pin and the source connection of the MOSFET, is used to program the appropriate voltage level to scale the slope compensation for correct use with the appropriate topology and set up conditions that have been adopted.

**Fixed Over Voltage Protection**

The T8332AD has a fixed over voltage protection which is implemented on the VSP pin. Once the VSP pin voltage over around 65.5V, the IC will stop the gate driver and the output voltage will drop. The hysteresis for the fixed over voltage protection is around 5V. Once the voltage on the VSP falls below around 60.5V, the IC will resume the switching on the gate driver.

*Note: For 430kHz, 8192 clock cycles equivalent to 19ms.*

**Over-temperature Protection**

If the chip temperature exceeds the over-temperature threshold T<sub>SD</sub> (~170°C), the IC will stop the gate driving. When the IC is shutting off, the IC’s temperature will begin to drop. Once the temperature drops around 135°C (the temperature hysteresis is 35°C typically).The IC will resume to start switching again.

**Output current adjustment by PWM control**

- **Directly driving EN input**

A pulse-width-modulation (PWM) signal with can be applied to the EN pin, as shown below, to adjust the output current to a value below the one programmed by  $R_{SENSE}$ .

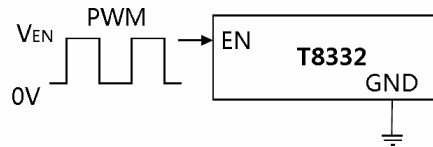

- **Driving the EN input from a microcontroller**

Another possibility is to drive the device from the open drain output of a microcontroller. The diagram below shows one method of doing this:

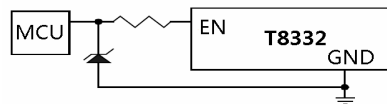

If the NMOS transistor inside the microcontroller has high drain capacitance / source capacitance, this arrangement can inject a negative spike into EN input of the T8332AD and cause erratic operation. The addition of a schottky clamp diode (cathode to EN) to ground and inclusion of a series resistor (10K) will prevent this. See the section on PWM dimming for more details of the various modes of control using high frequency and low frequency PWM signals.

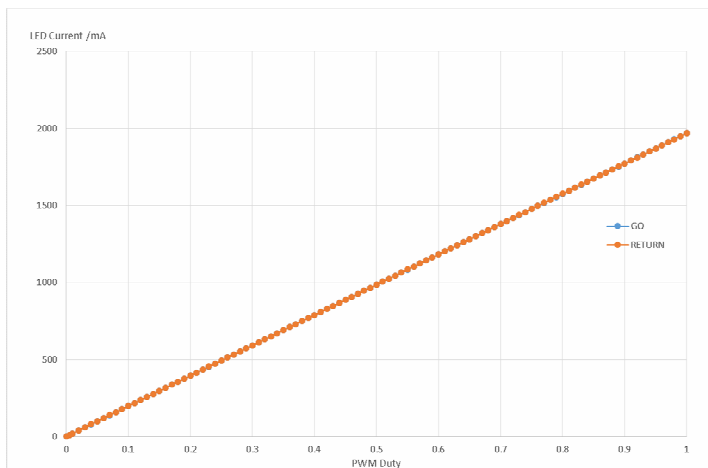

*PWM Switching Frequency = 100Hz  
Switching Frequency = 350kHz*

*PWM Dimming at 100Hz achieves 100:1 Dimming Ratio.*

*Testing Condition:  $V_{in} = 12V$ , LED voltage and full load current = 15V, 2A.*

**Output current adjustment by external DC DIM control voltage**

**DC Dimming**

The DIM pin can be driven by an external dc voltage, as shown, to adjust the output current to a value below the one programmed by  $R_{SENSE}$ .

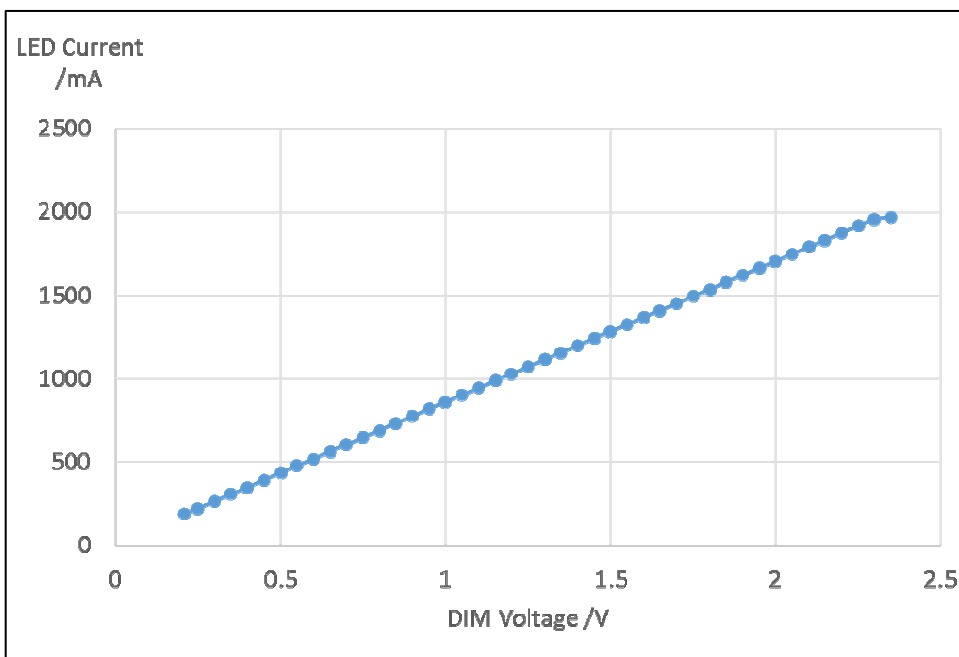
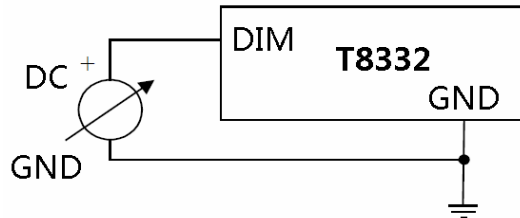

**TYPICAL APPLICATION CIRCUITS**

The T8332AD can be configured as Boost, Buck and Buck-Boost. The application circuits are shown below:

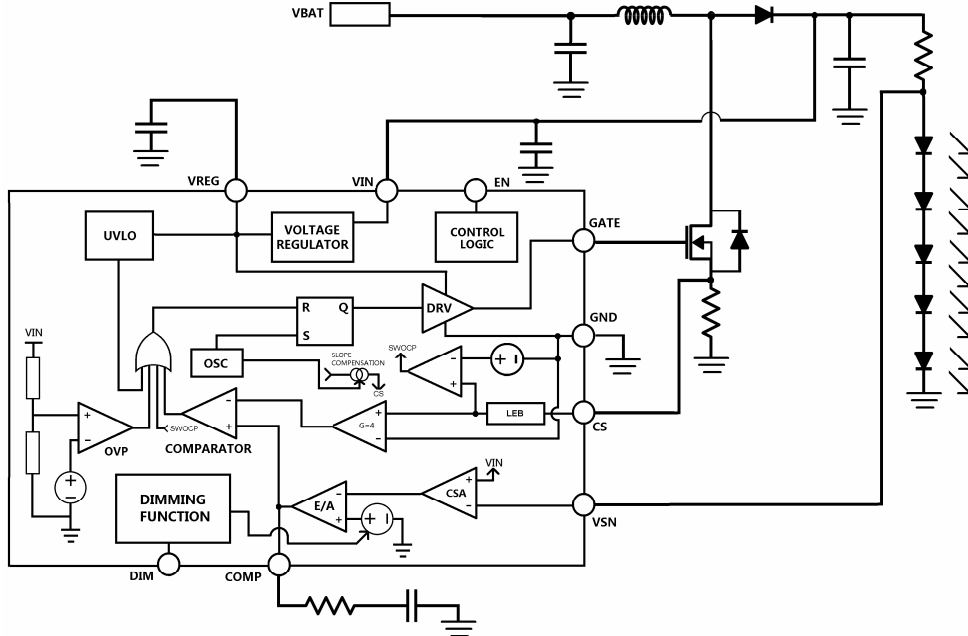

**Boost Converter which is for  $V_{BAT} < V_{LED}$ .**

*Note:  $V_{LED}$  must be less than MOSFET rating. ( $V_{BAT}$  max 60V)*

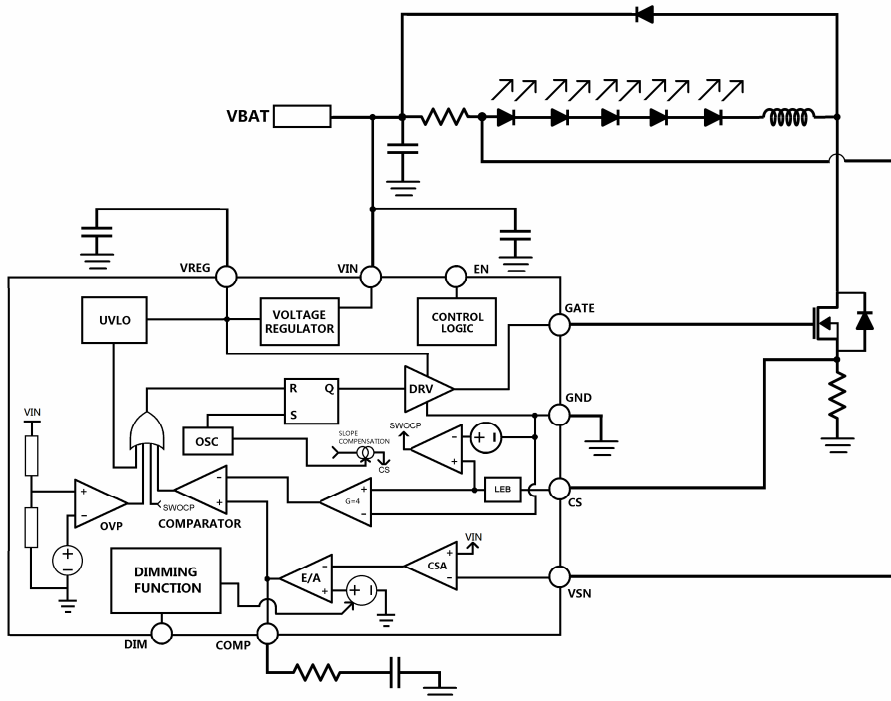

**Buck Converter which is for  $V_{BAT} > V_{LED}$ .**

*Note:  $V_{BAT}$  (max 60V) must be less than MOSFET rating.*

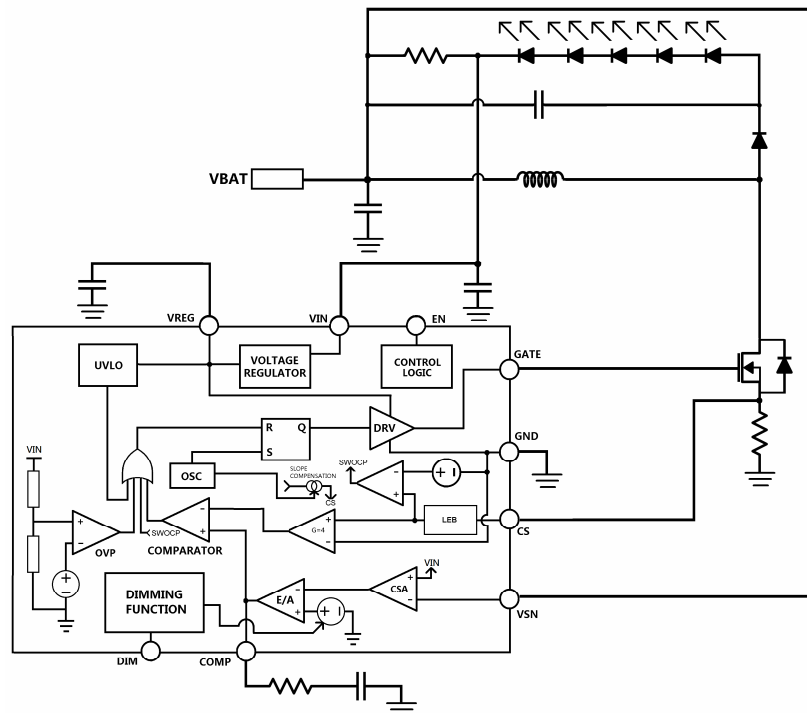

**Buck-Boost which is for  $V_{BAT} < V_{LED}$  or  $V_{BAT} > V_{LED}$ .**  
*Note:  $V_{BAT}(\text{max } 60V) + V_{LED}$  must be less than  $< +60V$  rating.*

**PACKAGE INFORMATION**

Package Type: 8 Lead SO8-EP

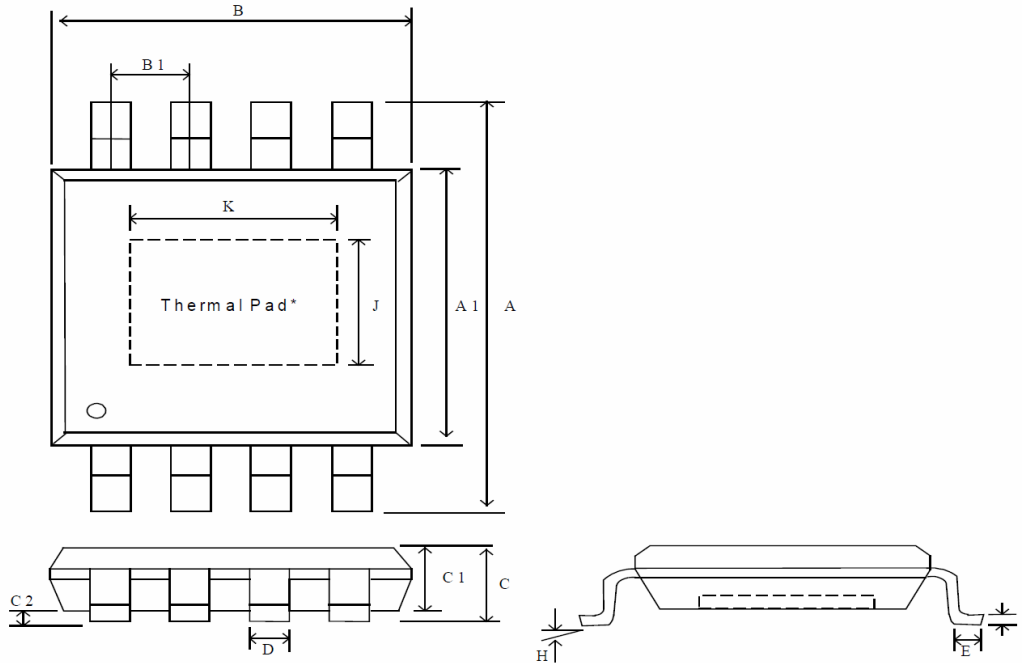

Symbol	Dimension in mm			Dimension in inch		
	Min.	Typ.	Max.	Min.	Typ.	Max.
A	5.70	6.00	6.30	0.224	0.236	0.248
A1	3.75	3.95	4.10	0.148	0.156	0.164
B	-	-	5.13	-	-	0.202
B1	-	1.27	-	-	0.050	-
C	-	-	1.80	-	-	0.071
C1	1.35	1.55	1.75	0.052	0.061	0.069
C2	0.10	-	0.25	0.001	-	0.004
D	0.31	0.41	0.51	0.012	0.016	0.020
E	0.30	0.50	0.70	0.012	0.020	0.028
F	0.10	0.15	0.25	0.004	0.006	0.010
J		2.23 REF			0.088 REF	
K		2.97 REF			0.117 REF	
H	0 ~ 8°			0 ~ 8°		