

## MCU for Optical Digital Diagnostic Monitor

### 1. Introduction

#### 1.1 General Description

The i7896 manages all system monitoring functions in a fiber-optic data transceiver module in accordance with SFF-8472 MSA. The IC communicates with a host system through an I<sup>2</sup>C bus, and can be programmed with a unique I<sup>2</sup>C address.

The IC offers temperature-controlled lookup tables for its two current DACs. Monitoring and calibration functions for supply voltage, temperature and three analog signals are available, as well as programmable alarm and warning flags for these signals which can be used to trigger interrupts based on user-specified limits. The memory is protected by a customizable two-layer password scheme. Furthermore, the memory layout can be configured to be compatible with the DS1856.

The i7896 is packaged in 16 pin TSSOP and LBGA.

#### 1.2 Applications

- Optical Transceiver
- Diagnostic Monitoring

#### 1.3 Ordering Information

Part No.	Package
i7896C	16-pin LBGA
i7896I	16-pin TSSOP

#### 1.4 Features

- Single +3.3V Power Supply, Five Monitored Channels (Temperature, V<sub>CC</sub>, MON1, MON2, MON3) Support Internal and External Calibration
- Internal Temperature Sensor Alarm and Warning Flags for All Monitored Channels
- Two Linear 8-Bit Current-Sink DAC with 5 User-Selectable Full-Scale Range (0.125, 0.25, 0.5, 1.0 and 1.5mA) Values Program Changeable Every 2°C
- Rx Power Monitor Range from 0.1uA ~ 1300uA with 10-bit Resolution
- Two Level Password Scheme Provides Three Levels of Security
- Provides All Optional and Required SFF-8472 MSA EEPROM (Both A0h and A2h Memory), SFF-8472 Compatible
- I<sup>2</sup>C-Compatible Serial Interface
- Pin compatible with DS1856/DS1859

#### 1.5 Pin Configuration

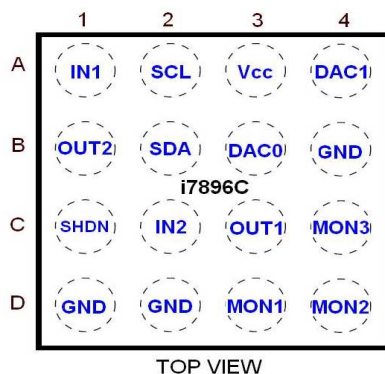

Figure 1. i7896C LBGA 16 configuration

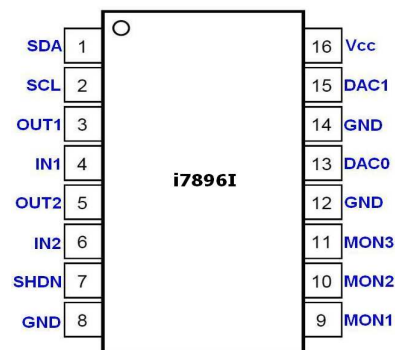

Figure 2. i7896I TSSOP 16 configuration