

# T62M99A

## Digital Sound Processor Embedded 48K Bits SRAM

### Features

- Operating voltage: 4.5V ~ 5.5V
- ADM algorithm
- Low noise ( -91dB typical)
- Low distortion rate (0.5% typical)
- Embedded 48k SRAM
- Automatic reset function
- Package type: 16-pin DIP/SOP

### Application

- Television
- Karaoke systems
- Video disc player (CD/VCD/DVD)
- Sound equipment with Echo Processor.
- Video tape Recorder
- Car stereo
- Electronic Musical Instrument

### Description

The T62M99A is an echo/surround effect processor designed for various audio system applications such as Karaoke, television, VCD/DVD, sound equipment ,..... Etc. It consists of a built-in Voltage controlled Oscillator, Embedded 48Kbits SRAM, A/D and D/A converters as well as echo/surround delay time control logic.

The embedded 48Kbits SRAM can generate delay time effect through the external VCO resistor control which simplifies the application and make it easy adjustment.

### Part Number Examples

Part NO.	Pkg.	Description
T62M99A-D	16-SOP	300mil-16-SOP
T62M99A-K	16-DIP	300mil-16-DIP

**Block Diagram**

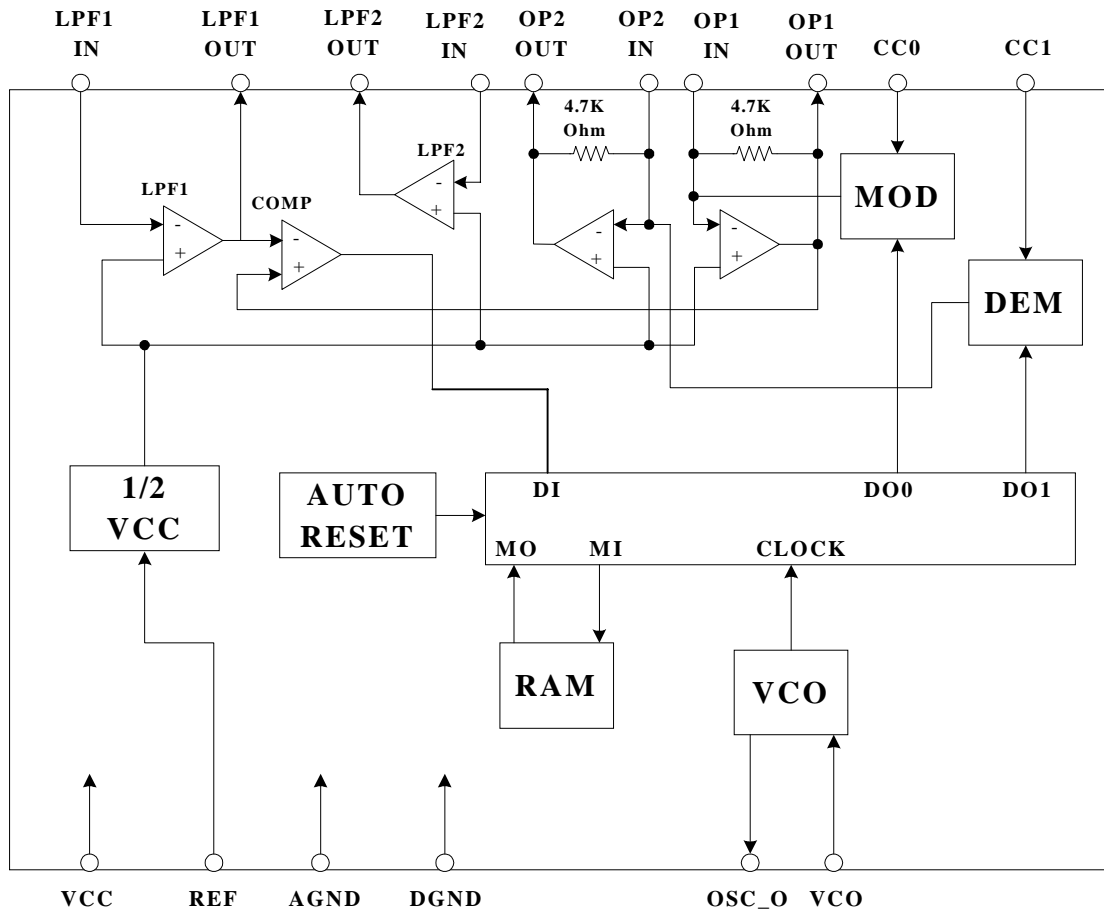

**Pin Configurations**

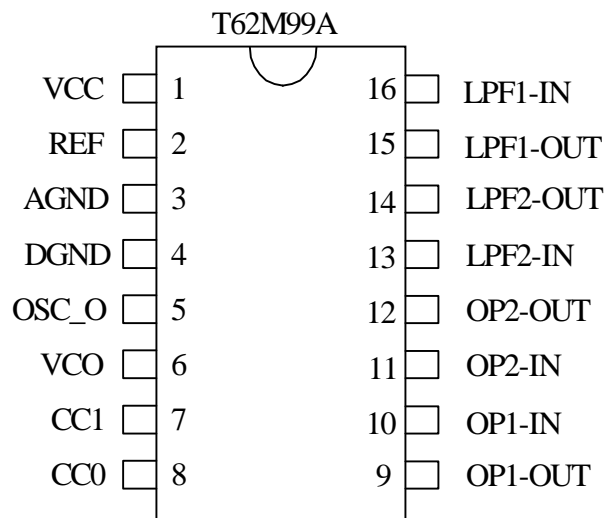

**Pin description**

Pin NO.	Pin Name	I/O	Description
1	VCC	-	Analog and positive power supply
2	REF	I	Analog reference voltage
3	AGND	-	Analog ground
4	DGND	-	Digital ground
5	OSC_O	I	System oscillator output
6	VCO	I	System oscillator input,system frequency adjustable pin
7	CC1	-	Current control1
8	CC0	-	Current control0
9	OP1_OUT	O	OP1 output
10	OP1_IN	I	OP1 input
11	OP2_IN	I	OP2 input
12	OP2_OUT	O	OP2 output
13	LPF2_IN	I	Low pass filter2 input
14	LPF2_OUT	O	Low pass filter2 output
15	LPF1_OUT	O	Low pass filter1 output
16	LPF1_IN	I	Low pass filter1 input

**Function Description**

The T62M99A is an echo/surround effect generator with embedded 48k bits SRAM. It ensures low distortion as well as low noise for processing audio signal delay. The chip provides two playing modes(echo and surround) and the playing functional block diagrams are shown as follows.

Surround Mode

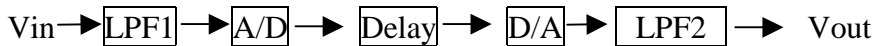

Echo Mode

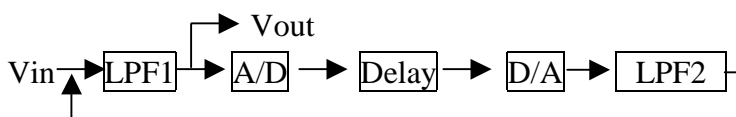

**Electrical Characteristics**

Ta=25°C

Symbol	Parameter	Test Conditions		Min.	Typ.	Max.	Unit
		VDD	Conditions				
V <sub>CC</sub>	Operating Voltage	-	-	4.5	5.0	5.5	V
I <sub>CC</sub>	Operating Current	5V	-	-	15	30	mA
G <sub>v</sub>	Voltage Gain	5V	R <sub>L</sub> =47KΩ	-	0.5	2.5	dB
V <sub>OMAX</sub>	Maximum Output Voltage	5V	THD=10%	1.0	1.5	-	V <sub>rms</sub>
THD	Total Harmonic Distortion	5V	30KHz L.P.F.	-	0.5	1.5	%
No	Output Noise Voltage	5V	DIN Audio	-	-91	-	dBV

**Absolute Maximum Ratings**

Supply Voltage .....	-0.3V to 6V
Input Voltage .....	V <sub>SS</sub> -0.3V to V <sub>DD</sub> +0.3V
Storage Temperature .....	-50°C to 125°C
Operating Temperature .....	-20°C to 70°C

Note: These are stress ratings only. Stresses exceeding the range specified as “Absolute Maximum Ratings” may cause substantial damage to the device. Functional operation of this device at other conditions beyond those listed in the specification is not implied and prolonged exposure to extreme conditions may affect device reliability.

## Application Circuits

### Echo Mode

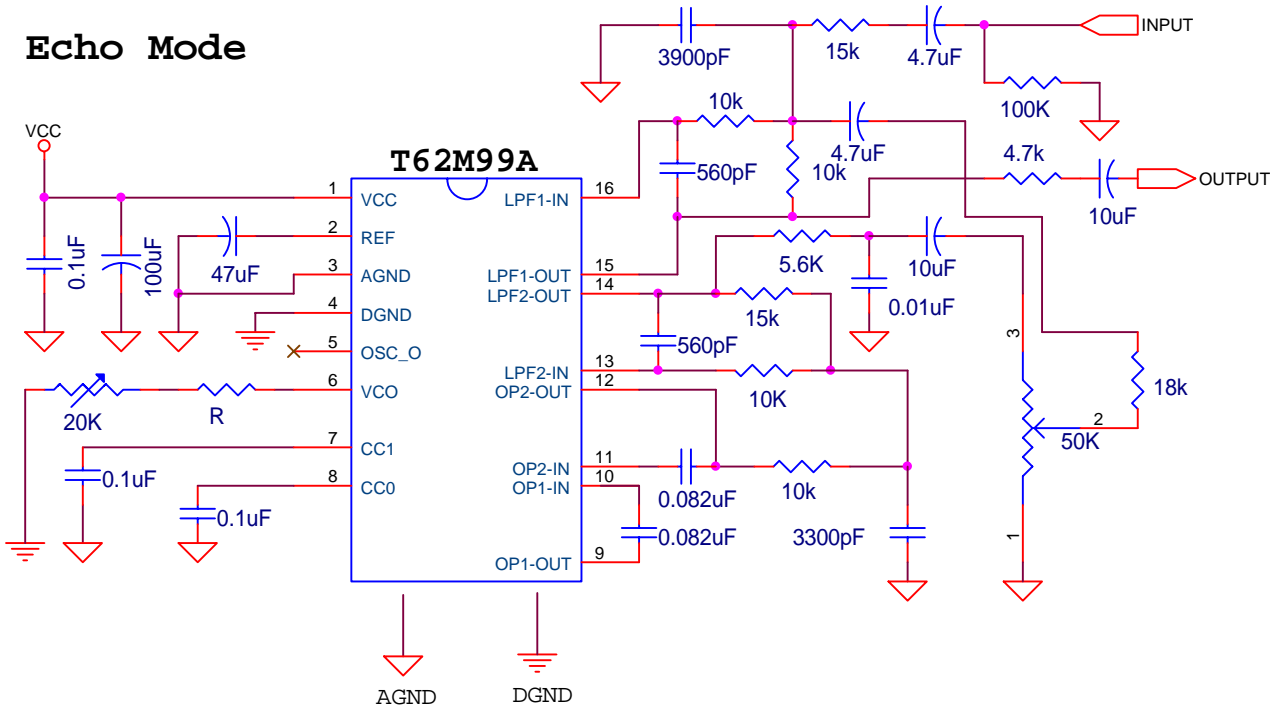

### Surround Mode

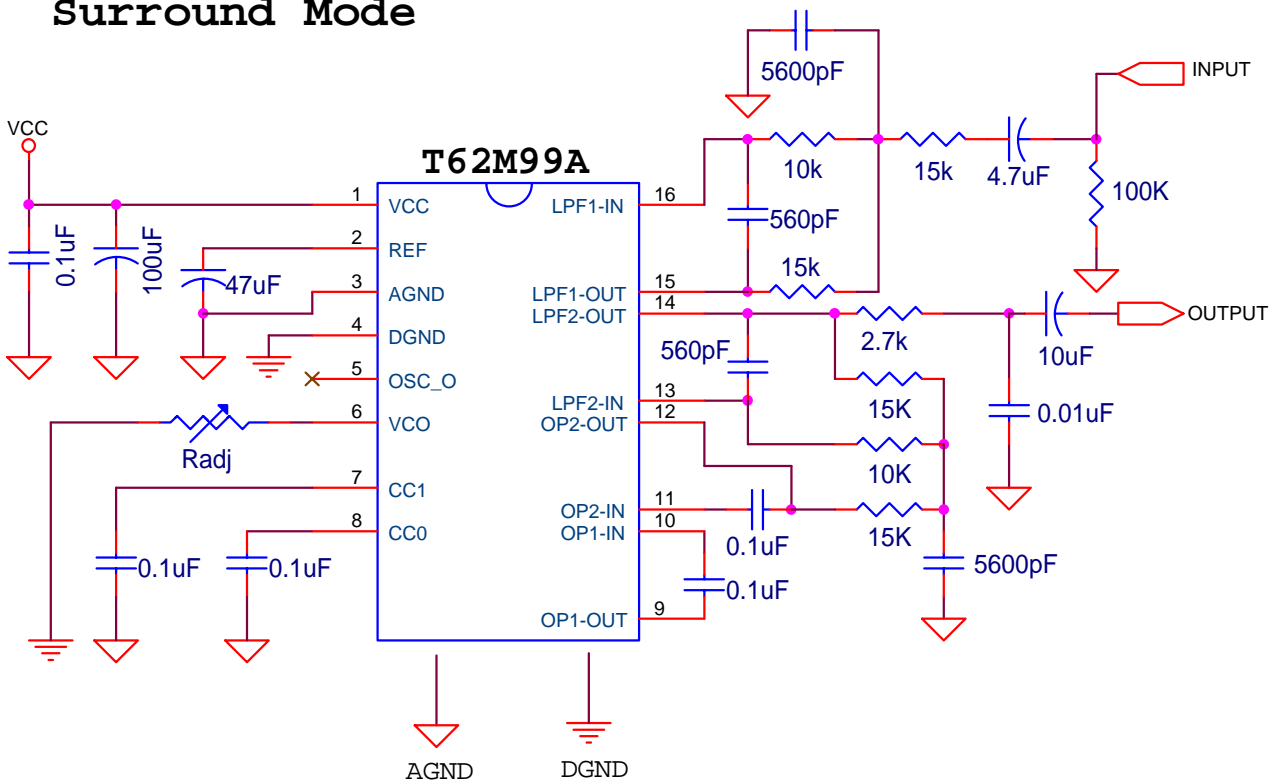

**Note:** "Radj" Value set delay time. R/delay time Reference on Resistance / Delay Time Table.

**Resistance / Delay Time Table .**

Radj	27.6K	21.3K	17.2K	14.3K	12.1K	10.5K	9.2K	8.2K
Fck	2.17M	2.75M	3.3M	3.83M	4.45M	5M	5.61M	6.05M
TD	357ms	282ms	235ms	198ms	172ms	152ms	137.4ms	125.3ms
THD+N%	0.95%	0.74%	0.59%	0.50%	0.43%	0.39%	0.34%	0.31%

Radj	7.2K	6.4K	5.8K	5.4K	4.9K	4.5K	4K	3.4K
Fck	6.71M	7.23M	7.8M	8.42M	8.94M	9.37M	10.1M	11.3M
TD	112.8ms	104.1ms	96ms	89.2ms	83.3ms	79.2ms	72.8ms	64.8ms
THD+N%	0.28%	0.26%	0.24%	0.23%	0.22%	0.22%	0.20%	0.19%

Radj	2.8K	2.4K	2K	1.67K	1.47K	1.28K	1.08K	894
Fck	12.6M	13.5M	14.4M	15.4M	16M	16.6M	17.4M	18.1M
TD	57.7ms	53.6ms	49.9ms	46.5ms	44.1ms	42.9ms	40.6ms	38.7ms
THD+N%	0.18%	0.16%	0.15%	0.15%	0.15%	0.15%	0.14%	0.14%

Radj	723	519
Fck	18.8M	19.9M
TD	37.2ms	34.9ms
THD+N%	0.14%	0.13%

Note :This Table is for Surround Mode.

R<sub>adj</sub>= External Resister for adjust FCK & TD.

FCK= Oscillate output Frequency for Pin 5 .(Unit : MHZ)

TD=Delay Time for audio output.

THD=Total Harmonic Distortion. (TDH+N Ratio %)

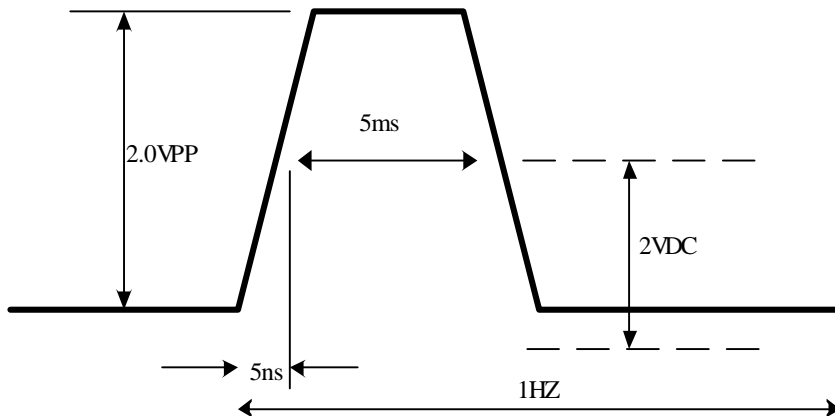

Pulse Clock Waveform for input Pin

**PACKAGE DIMENSIONS**

16-LEAD SOP ( Unit:mm )

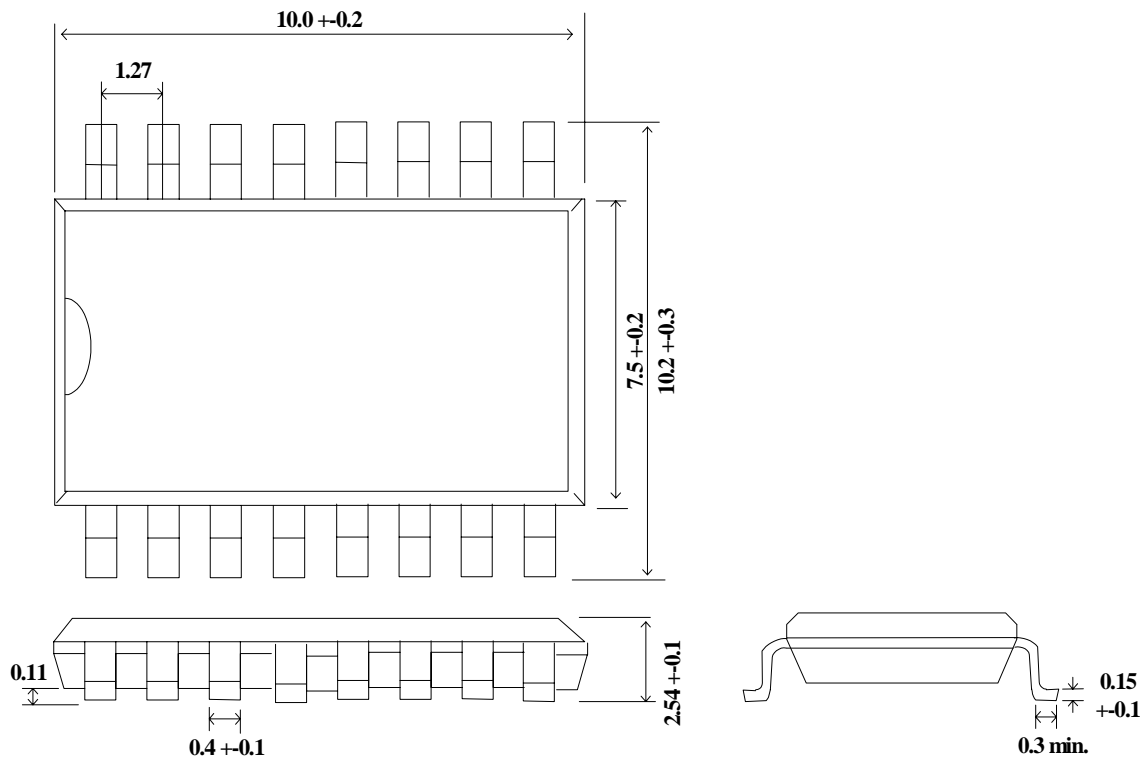

16-LEAD DIP ( Unit:mm )

